

PT-60 TYPE

※ PIPE 가공 전용 For PIPE machining
 ※ 적정 RPM(3800이하) Optimal RPM(below 3,800)

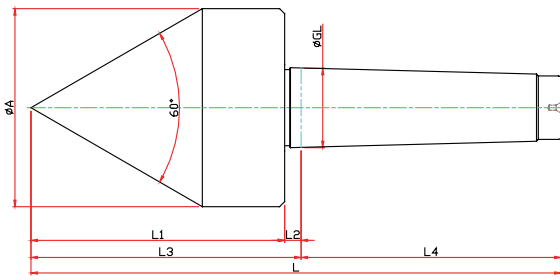

Model	Order Number	Morse Taper	Dimension							Weight MAX.	R.P.M MAX.	Run Out
			GL	A	L1	L2	L3	L4	L			
LC-2PT-60	066002	NO.2	17,780	44	66	5	71	64	135	70	4500	0.003
LC-3PT-60	066003	NO.3	23,825	56	78.5	5	83.5	81	164.5	80	4500	0.003
LC-4PT-60	066004	NO.4	31,267	78	100	6.5	106.5	101.5	208	80	4500	0.003
LC-5PT-60	066005	NO.5	44,399	98	125	6.5	131.5	129.5	261	230	2000	0.005
LC-6PT-60	066006	NO.6	63,384	118	154	8	162	182	344	600	1500	0.005

PT-80 TYPE

※ PIPE 가공 전용 For PIPE machining
 ※ 적정 RPM(3800이하) Optimal RPM(below 3,800)

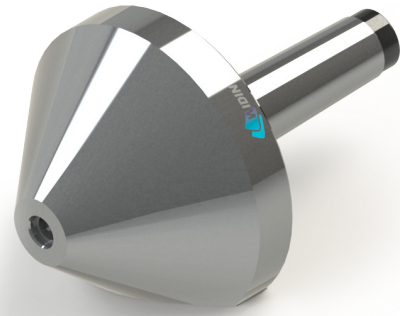
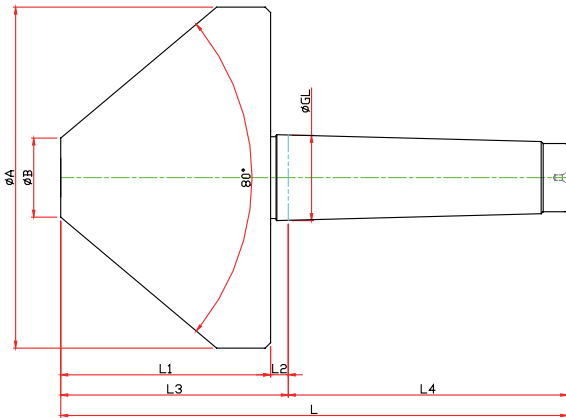

Model	Order Number	Morse Taper	Dimension								Weight MAX.	R.P.M MAX.	Run Out
			GL	A	B	L1	L2	L3	L4	L			
LC-3PT-80	068003	NO.3	23,825	95	20	66	5	65	81	146	190	3800	0.003
LC-4PT-80	068004	NO.4	31,267	125	29	77	6.5	83.5	102.5	185	190	3800	0.003
LC-5PT-80	068005	NO.5	44,399	150	32	90	6.5	96.5	129.5	226	350	2000	0.005
LC-6PT-80	068006	NO.6	63,384	200	38	120	8	128	182	310	1200	1500	0.005

NC-TYPE

NCP-TYPE

NK · NKD TYPE

GR · SM TYPE

SMP-TYPE

D50 TYPE

HD-TYPE

PT-TYPE

LM CENTER

LM-H CENTER